

A large industrial facility, likely a coal-fired power plant, is shown at night. The plant is illuminated with warm yellow lights, and several tall, red and white striped smokestacks are visible. The plant is situated behind a line of green trees, and a body of water in the foreground reflects the lights and the structure of the plant.

COAL-FIRED POWER GENERATION

Even with the renewable power market rapidly expanding, Coal-Fired power remains the leading power generation source worldwide. Increasingly stringent environmental regulations meant to reduce greenhouse gas emissions require coal-fired plant operators to ensure efficient operation. To achieve this, plants need a reliable actuation technology with high frequency response, hydraulic stability, and no oil maintenance. This is why more coal-fired plant operators are switching to REXA's Electraulic™ Actuators!

Upgrading coal-fired power plant applications with REXA's Electraulic™ Actuation offers unmatched reliability, problem-free startup, and maximum availability. REXA Actuators and Damper Drives allow plant operators to optimize control of pressures, temperatures, airflow, and other key process loops. The resulting improved operations from unit turndown capability, ramp rate and reduced fuel consumption make it easier for plants to stay in compliance with regulations.

At REXA, we have more than 35 years of experience in the Coal-Fired power market. We offer high-quality, low maintenance Electraulic™ Actuators that have been field-proven in the most critical and difficult applications:

Forced draft, induced draft & primary air dampers

Attemperator spray valves

Main feedwater / recirculation control

Sky vent valves

Supercritical startup valves

Steam drains

Burner tilts

Sootblower valves

Why REXA?

The REXA XPAC Electraulic™ Actuator is a superior positioning device well suited for critical control applications, such as those found in combined cycle plants. It controls severe process conditions in harsh environments and provides high reliability. REXA Electraulic™ actuators and drives provide the final control element capabilities to match the most sophisticated instrumentation and distributed control systems.

The XPAC is comprised of the mechanical subassembly and the electrical subassembly. The mechanical subassembly consists of a double acting hydraulic cylinder, position feedback sensor and an Electraulic™ Power Module. The power module is a unique, self-contained, sealed hydraulic pumping system which manages oil pressure and flow to and from the cylinder. The electrical subassembly consists of the power supplies, motor drivers, and a dedicated microprocessor.

The combination of these mechanical, hydraulic and electronic technologies ensures accurate and repeatable control of combined cycle plant processes.

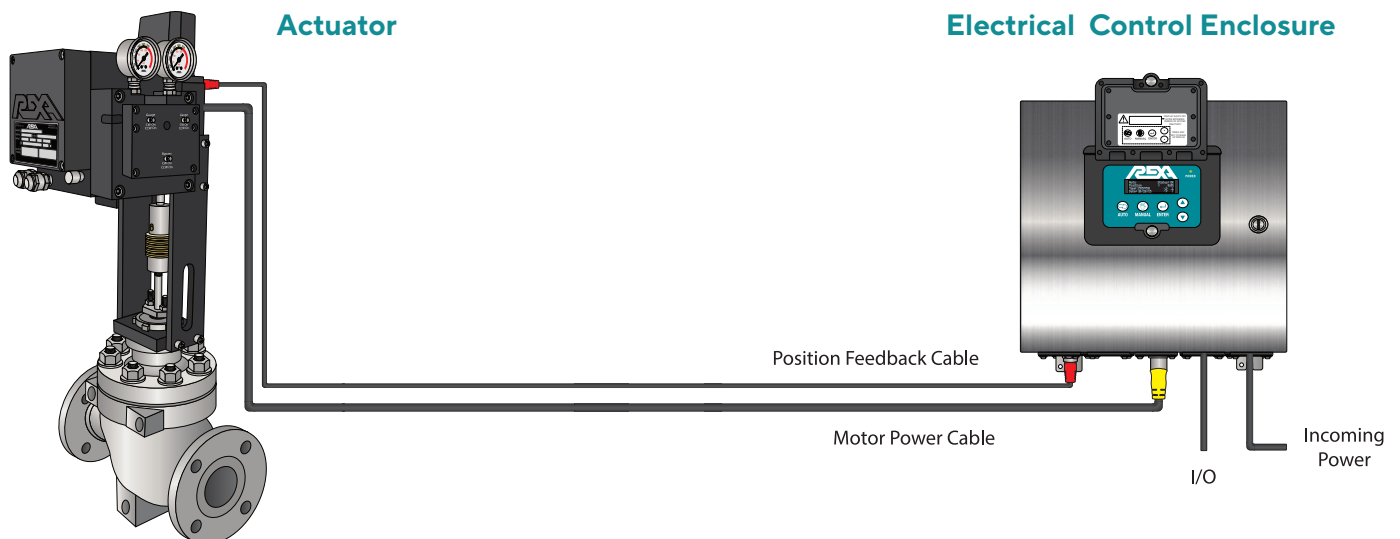

Coal-Fired Damper Control

Furnace draft pressure control is the heart of complete combustion, reduced fuel consumption, and increased plant efficiency. Pulverized coal fans and dampers are the key elements in making all of this happen. Primary Air (PA) fans deliver the required fuel from the pulverizers to the furnace to meet generation demand. In a balanced draft arrangement, both Forced Draft (FD) and Induced Draft (ID) fans are used to control air and combustion gas flow through the boiler. The most common, balanced draft systems operate slightly below atmospheric pressure to ensure safe operation and the removal of flue gas from the furnace. Inadequate FD/ ID operation negatively affects the performance of low NO_x burners that have narrow limits for flammability and need precise fuel/air ratios to work as designed. Poor damper performance, along with inadequate pulverization, are the main contributors of increased fly ash.

This results in slagging and fouling, ultimately leading to increased thermal fatigue of boiler tubes and subsequent leaks. Load rejection scenarios and turbine upset conditions have the potential to wreak havoc on the stability of furnace draft pressure. Air supplied to the boiler is separated into primary and secondary streams. The primary air is critical in heating the coal to the right temperature based on plant load. Dampers, able to track changes, prevent the coal from becoming too wet, and eliminate the risk of a pulverizer fire. Secondary air fed through the airbox and controlled by dampers is critical for complete combustion. Whether it is for a wall fired or tangentially fired boiler with low NO_x burners, these air dampers are the final control element and the determining factor for the highest efficiency.

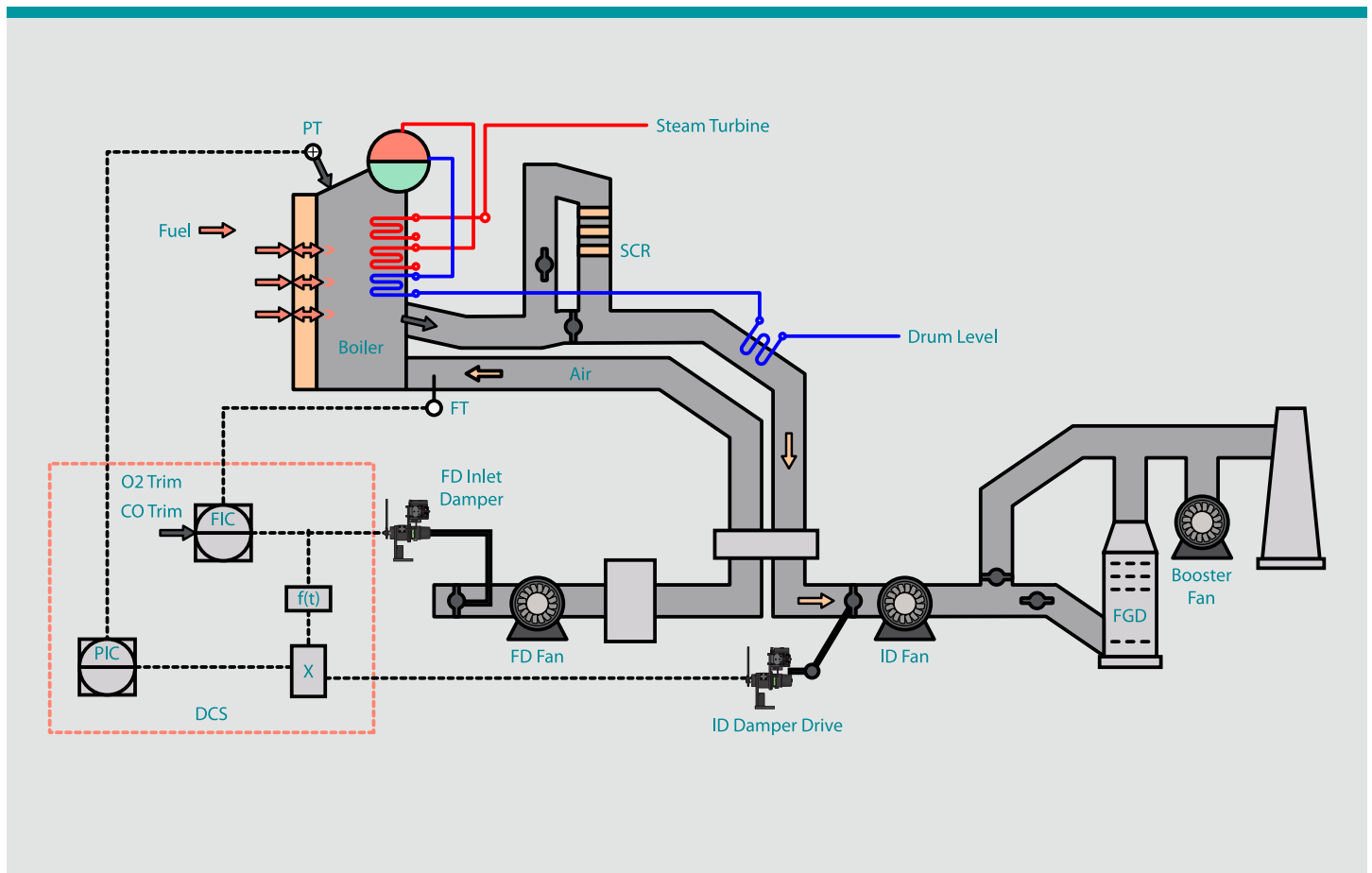

Primary Air Dampers

A key component of a coal-fired steam plant is the Primary Air (PA) fan and damper. Coal is first crushed into fine particles or dust using pulverizers. The purpose of the primary air fans is to carry the coal dust to the burners as fuel for combustion. Within the PA system, there can be many dampers to balance based on coal type and ambient conditions, including air heater, cold air, hot air and primary dampers.

Dampers must function at a high level to prevent problems with the feed system to the furnace. An improperly modulating cold air damper may leave the coal particles too wet, creating a buildup and potential blockage in the ductwork. A poorly functioning hot air damper can result in coal that is too hot, risking a fire in the system. Once the cold air and hot air dampers do their jobs, the PA damper then modulates the conditioned air to the pulverizer and burners.

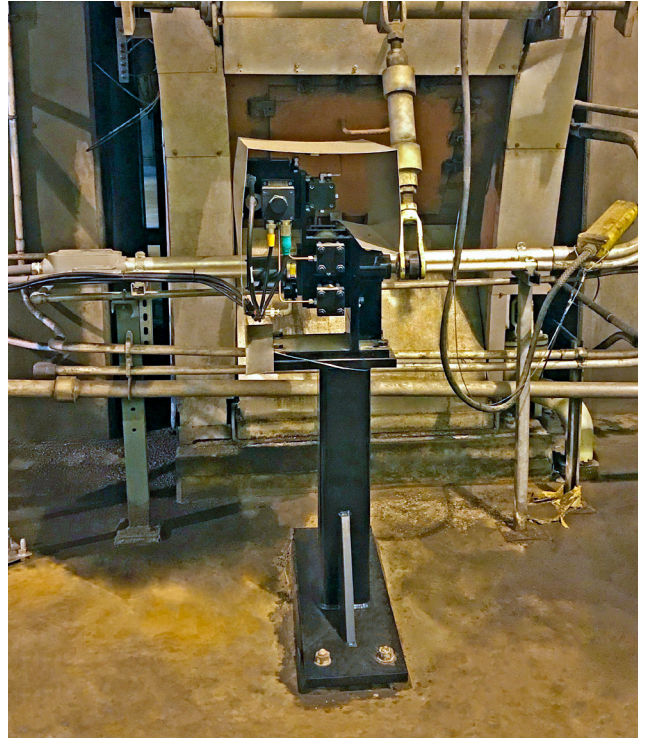

Forced Draft and Induced Draft Air Dampers

Fans and dampers play an important role balancing the air flow in a boiler system, ensuring an efficient combustion process. Forced Draft (FD) and Induced Draft (ID) fan dampers are the primary drivers to reduce emissions and improve heat rate. Though these dampers work together, they differ in purpose. Forced Draft (FD) Fans force outside air through a preheater into the furnace. ID Fans, which are normally located downstream near the Flue Gas Desulfurization system (FGD), draw flue gas from the system and move it through the stack to the atmosphere.

Dampers must respond to control signal changes quickly and modulate accurately to always maintain a slight negative pressure in the furnace for proper flue gas flow. In the event of a turbine load shed, it is critical that dampers close quickly to prevent a combustion chamber pressure increase through a furnace draft excursion.

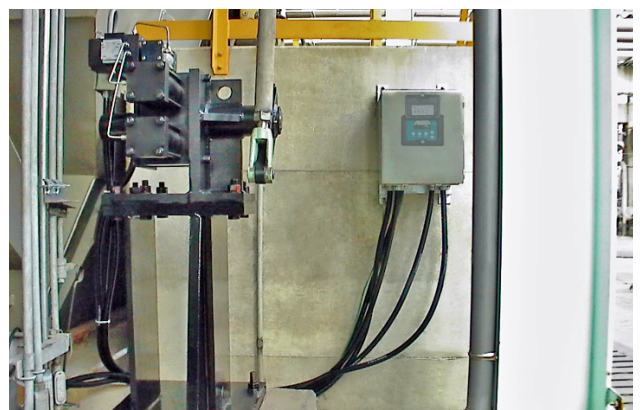
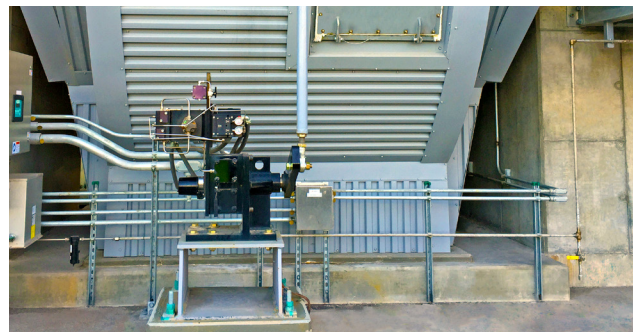

Burner Tilt

Primarily found on tangentially fired pulverized coal boilers, burner tilt assemblies angle corner burners in unison +/- 30 degrees towards the center of the fire box to maintain control over steam temperature. Tilt angle plays an important role in quality of combustion and NOx emissions by shifting the flame zone across the furnace height. A swirling motion is created inside the boiler, enabling the separation of air and fuel around the central vortex. This delays the combustion process and the formation of NOx - a benefit of the tangential fired system. If burners are unable to be located at the proper angle or evenly based on boiler load, a more complete combustion may take place at the wrong time. This affects steam temperature and increases NOx emissions.

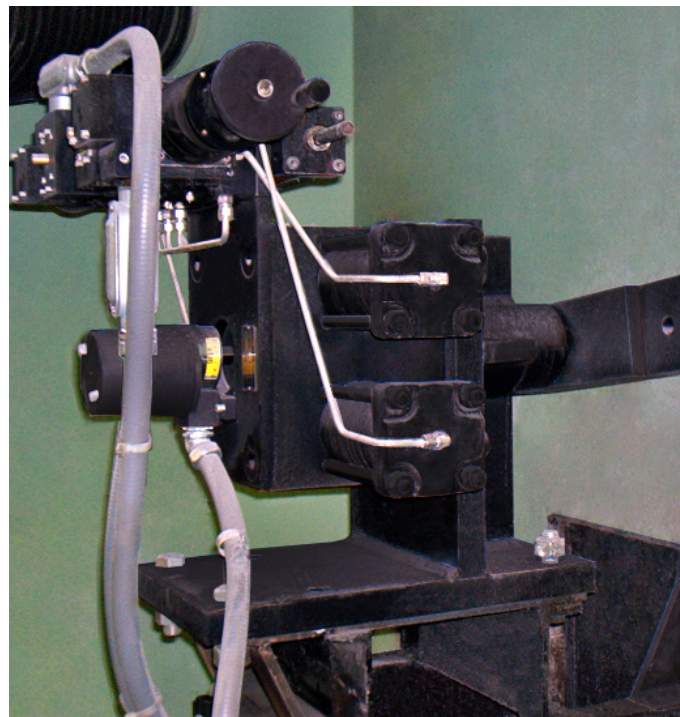

Sootblower

The sootblower system is an integral part of the boiler and key to effective steam generation. In the combustion process where solid fuels are used, ash deposits on boiler tube surfaces, causing slagging and fouling. This soot must be removed for proper heat transfer and to prevent tube damage. There are various types of sootblowers, including wall and retractable designs, with steam as the common medium.

Sootblower heads are fed through a common line, with a sequential blowing routine for different areas of the boiler. High pressure steam is reduced through a header valve, to a working pressure that energizes the various sootblower "trains". The header valve continuously modulates during this process. Precise modulation with fast stroking speeds allows the system to come up quickly and keep the retractable heads cool. Tight shutoff is also critical when the sootblowers are not in use to prevent the header safety valve from lifting.



Supercritical Plant Startup Control

Supercritical and Ultra-Supercritical plants are best suited to remain a vital part of global power generation for decades to come. They operate above the critical pressure and temperature of water (3206.2 psia at 705.4° F), up to a maximum of 4350 psia and 1170° F. Since feed water is turned into steam as it travels through the boiler tubes, the operation of the startup system becomes extremely important. The startup system in once-through critical pressure units from various manufacturers all serve the same purpose, and that is to roll and synchronize the turbine. An orderly startup sequence and initial unit load is made easier and faster with predictable actuation. During heat build-up in the boiler, both the water and steam in the flash tank/ separator are directed to the deaerator through the pegging valve and feedwater heaters.

Once the enthalpy level in the flash tank reaches a desired level, steam is admitted to the superheater and main steam lines for warming. In reference to a CE process (see diagram below), it is then bypassed to the condenser through the steam drain/turbine bypass (SD) valves, which better match the steam temperature to the turbine metal temperature prior to rolling. It is through these valves that steam flow is admitted to the superheater through the Throttle Bypass (TB) valves, and the flash tank/separator is taken out of service. It is critical that these bypass valves are accurately controlled, so the outlet steam temperature can be maintained to straight through operation, and opening of the throttle (BT) valves. The DCS uses the bypass system during startup and low load operation for feedwater pressure and flow control.

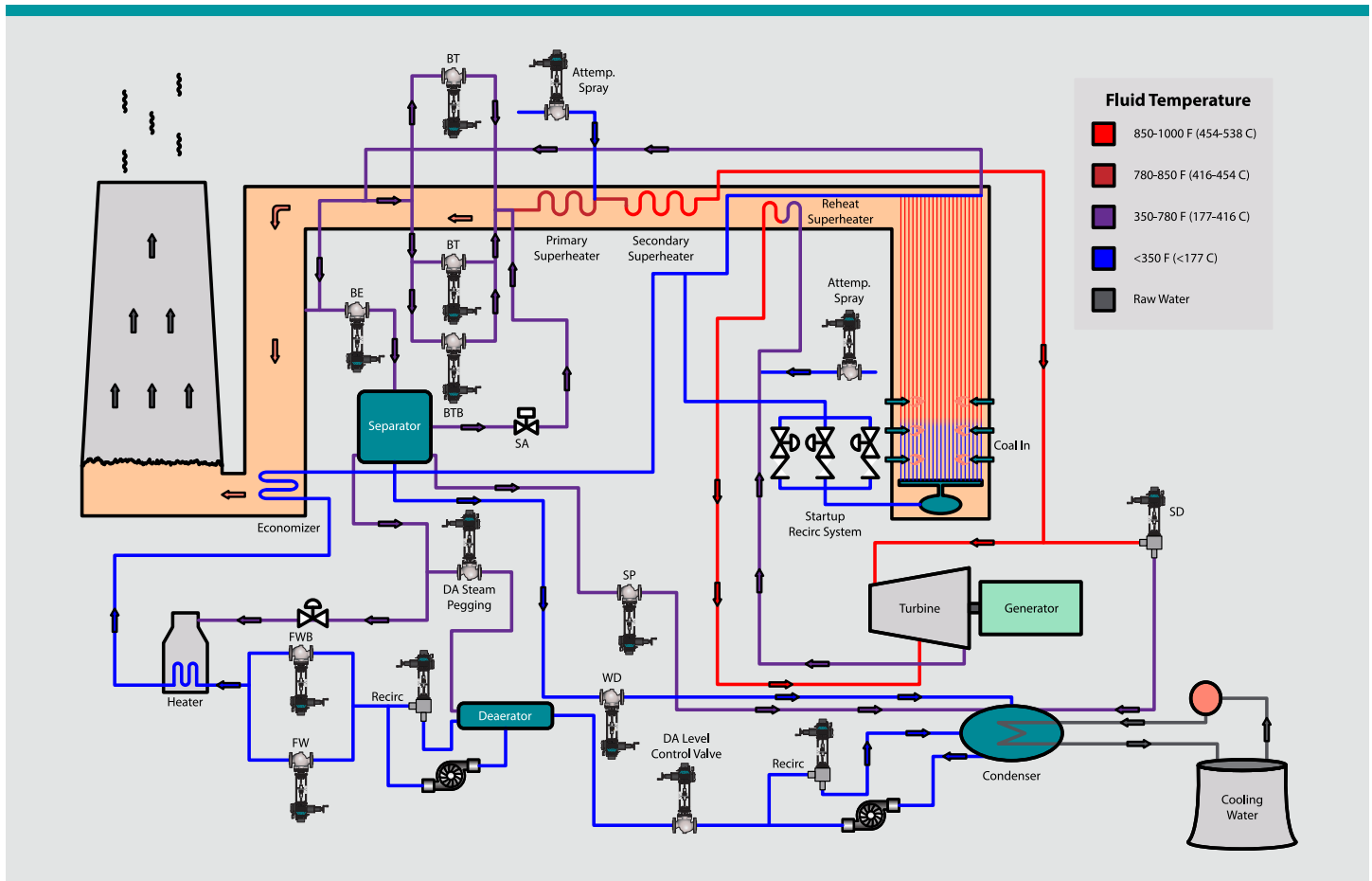

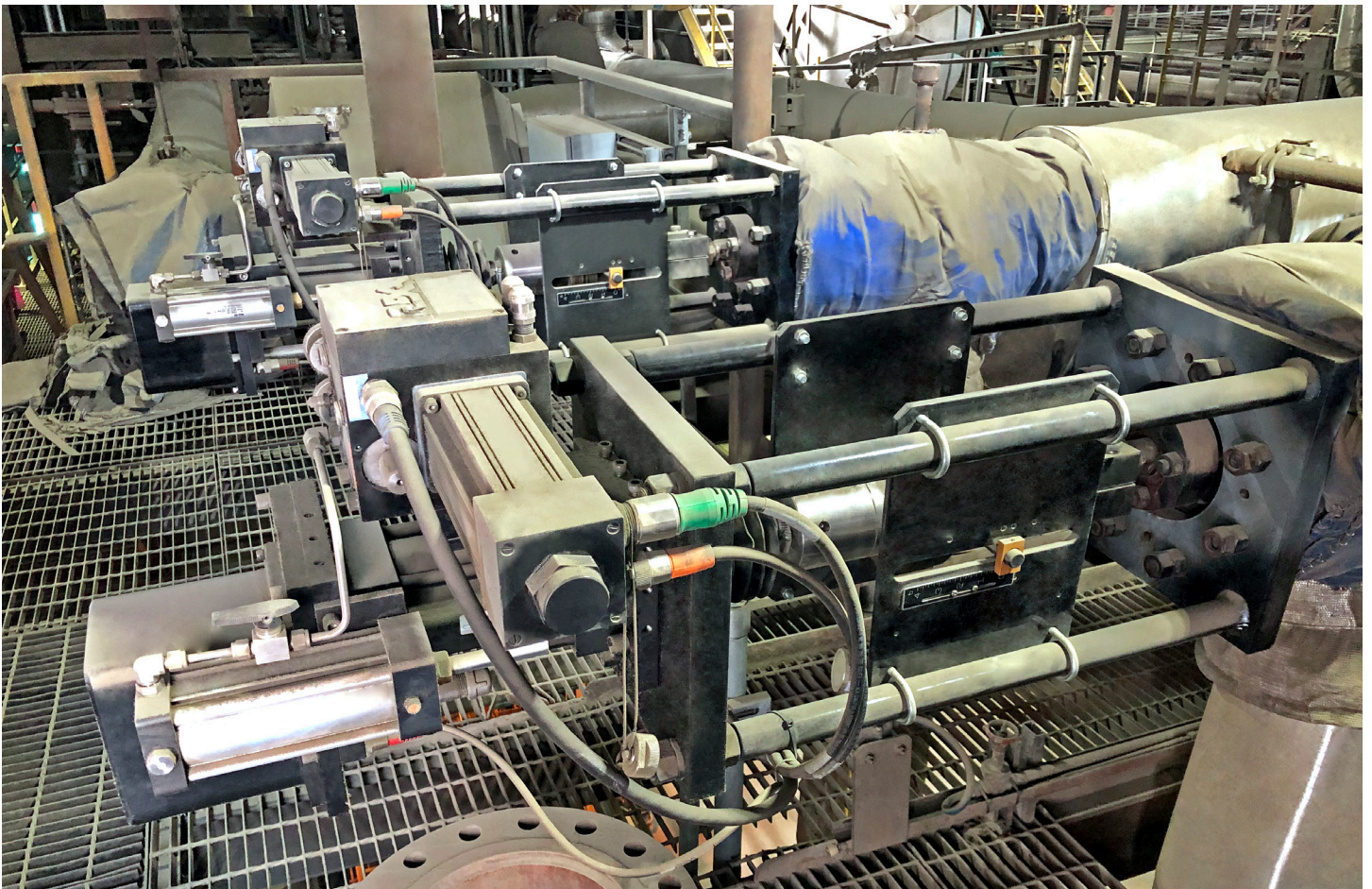

Feedwater Control

The feedwater regulator is the pathway from which feedwater is fed into the boiler. Its primary purpose is to maintain drum level during operations, continuously modulating through boiler cycling due to varying grid requirements.

During startup, the feedwater valve must precisely control flow to increase ramp rate. Load changes can be exceptionally troublesome due to the drum level “shrink and swell effect”. Increased steam demand causes a drop in drum pressure, which creates larger vapor bubbles that raise drum level. During a reduced output load swing, drum pressure increases, causing a reverse effect on the vapor bubbles and a decrease in drum level. The feedwater valve must have high-resolution with immediate signal response to prevent excessive swings. On a load shed, it is critical that the feedwater valve react with minimal dead time to prevent water carry over and turbine damage.



Boiler Feedwater Recirculation Valve

Maintaining a minimum flow through the feed pump is critical in preventing cavitation and eventual catastrophic damage. The Feed Pump Recirculation Valve protects the pump at all load conditions, bypassing the boiler and directing feedwater to the deaerator or main condenser.

During a boiler trip or other upset condition, the recirculation valve must open quickly, diverting high pressure feedwater away from the pump. As one of the most severe services in the plant, the recirculation valve is subjected to full feed pump pressure on the inlet and a low outlet pressure. At a preheated temperature, cavitation is imminent and is treated with multi-stage valve trims. The recirculation valve is closed for normal boiler operations, resulting in a high pressure drop and the need for Class V or better shutoff. The valve must be capable of remaining tightly closed to prevent major trim/body damage and reduce heat rate.



Superheat Attemperator

The necessity to stabilize the grid from many power generation sources can cause continually varying boiler loads in coal-fired plants. Maintaining a constant steam temperature to the turbine during these ramping periods is the goal, which ensures optimum heat rate and protects the boiler.

Located between the primary and secondary superheaters, the superheat spray valve is the final control element protecting the turbine against damaging temperature swings. Accurate and repeatable valve position can be a challenge during cycling, especially in low load conditions. Instability due to damaged trim, problematic actuation and excessive deadtime, can lead to moisture carryover into the secondary superheater causing catastrophic tube failure. With inadequate attemperation, operators may program the control system to prevent low flow operation, limiting plant flexibility.



Reheat Attemperator

The addition of reheater tube banks in a boiler ensures higher plant efficiency and reduces overall heat rate. After much of the heat energy is used in the HP turbine as high pressure superheated steam passes through, the reduced pressure/temperature steam is directed out of the turbine to the cold reheat line and back into the boiler. It is then reheated and sent to the LP turbine for additional MW generation. The reduced pressure of reheat steam means a lower pressure differential across the spray valve often causes cavitation – leading to the need for flow treatment. The challenge is maintaining stable valve position with precise spray water control. If reheat valve trim is damaged from cavitation and unable to maintain proper temperature to the turbine, the unit is usually brought down to 50-60% power where attemperation is not needed. It remains at that level until a rebuild can be performed.



Turbine Bypass Systems

The bypass system plays an integral part in plant operators' overall goal of a controlled steam turbine startup and shutdown. Base load units that perform low load and load cycling operations can struggle in this area and experience increased damage to power generation equipment. An improperly functioning Hydraulic Power Unit driving turbine bypass valves often leads to unstable main and reheat steam pressures, rapid fluctuations in temperature, and ultimately catastrophic tube failures.

Nuisance trips during ramp-up and ramp-down scenarios can cause instability in other areas of the plant, including feedwater systems and furnace draft pressure control. These upsets can result in extensive on-line delays, increased heat rate, and startup fuel/chemical costs.

In the event of a turbine trip due to load shed or a boiler trip, bypass valves must come open in less than a second to divert steam away from the turbine and prevent an overspeed condition.

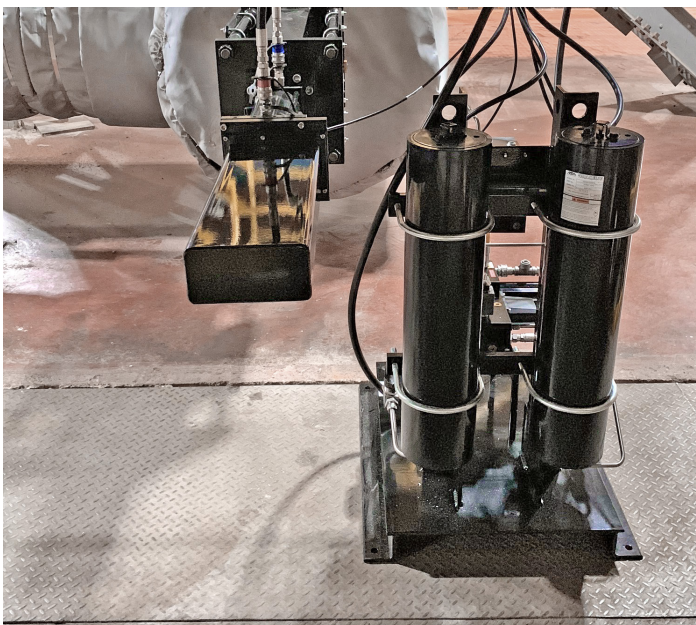
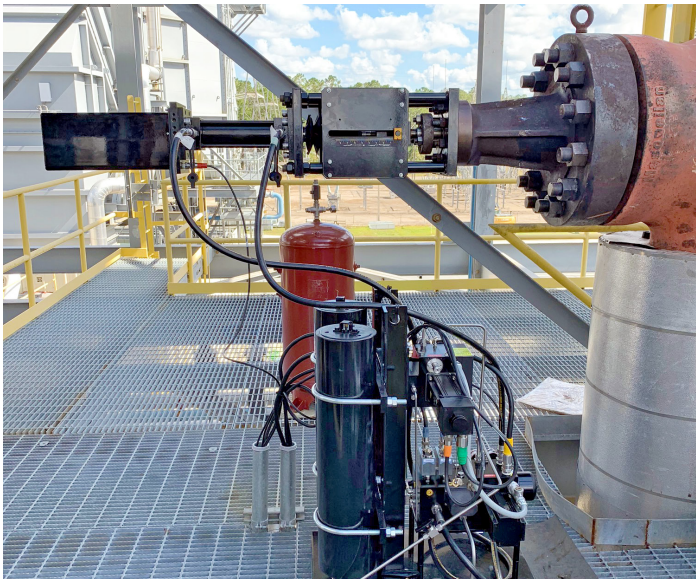

Steam Turbine Governor Control

Found in all coal-fired power plants, steam turbines are the primary drivers for boiler feed pumps and generators. Both have a turbine governor system that maintains rotational speed as a constant in response to changing load conditions. This is accomplished by adjusting the position of a steam inlet valve(s), thereby regulating steam flow to the turbine. Variations in load can greatly impact turbine performance, potentially varying the designed output frequency. In addition, boiler control, ramp rate, and the ability to synchronize to the grid may be impacted.

Hydraulic Power Unit (HPU) driven systems are preferred over other technologies for control, but are difficult to maintain and can progressively become unreliable with age. Extensive oil maintenance is a necessity for proper operation. Open-loop systems are prone to contamination with moisture and other contaminants, resulting in oil breakdown from oxidation and acid build up. In addition, the continuous circulation of oil adds heat to the system, accelerating degradation of the hydraulic fluid.

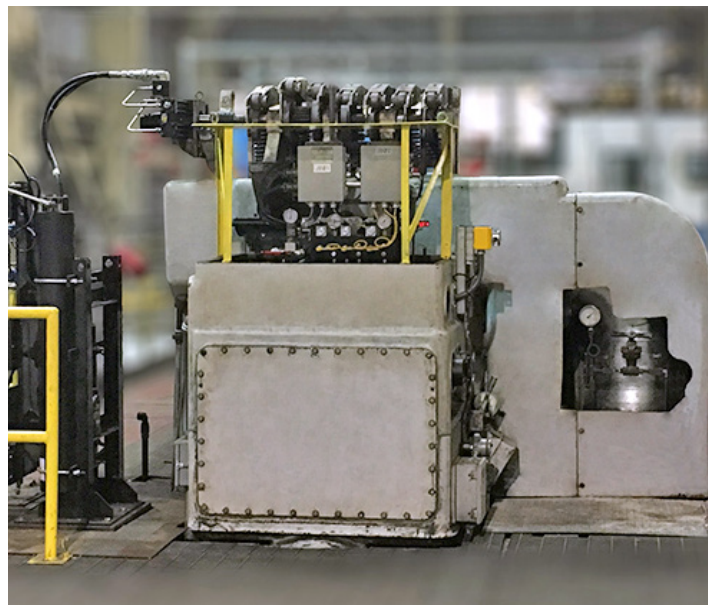



Headquarters & Factory

REXA, Inc.
4 Manley St.
West Bridgewater, MA 02379
Tel: 508-584-1199

Sales, Service, & Training

REXA, Inc.
20338 Telge Road, Building E
Tomball, TX 77377
Tel: 281-944-4490

Sales & Service

REXA, Inc.
7110 Oak Ridge PKWY. Suite 170
Austell, GA 30168
Tel: 770-857-0003



www.rexa.com

IB-8_12.24